

GP1S50J0000F

Gap : 3mm, Slit : 0.5mm
Phototransistor Output,
Case package Transmissive
Photointerrupter



■Description

GP1S50J0000F is a standard, phototransistor output, transmissive photointerrupter with opposing emitter and detector in a case, providing non-contact sensing. For this family of devices, the emitter and detector are inserted in a case, resulting in a through-hole design. The case includes additional screw fixing holes, on both sides 3.2mm diameter.

■Features

1. Transmissive with phototransistor output
2. Highlights :
 - Vertical Slit for alternate motion detection
 - Includes additional screw fixing holes
3. Key Parameters :
 - Gap Width : 3mm
 - Slit Width (detector side) : 0.5mm
 - Package : 25 × 10 × 6mm
4. RoHS directive compliant

■Agency approvals/Compliance

1. Compliant with RoHS directive (2002/95/EC)

■Applications

1. General purpose detection of object presence or motion.
Example : Printer, FAX, Optical storage unit

Notice The content of data sheet is subject to change without prior notice.

In the absence of confirmation by device specification sheets, SHARP takes no responsibility for any defects that may occur in equipment using any SHARP devices shown in catalogs, data books, etc. Contact SHARP in order to obtain the latest device specification sheets before using any SHARP device.

Sheet No.: OP14023EN

■ Internal Connection Diagram

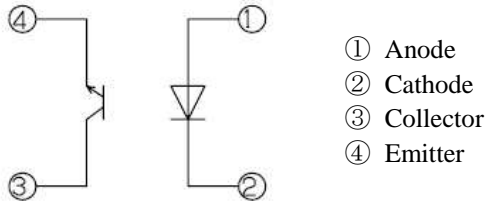

■ Outline

Drawing No. CY13290i02

Unit : 1/1 mm

1) Unspecified tolerances shall be followed the list below.

Dimension	Tolerance
$d \leq 6$	± 0.1
$6 < d \leq 18$	± 0.2
$18 < d \leq 25$	± 0.25

2) Dimensions in parenthesis are shown for reference.

3) portion: Company name, Model No., and Date code shall be marked.

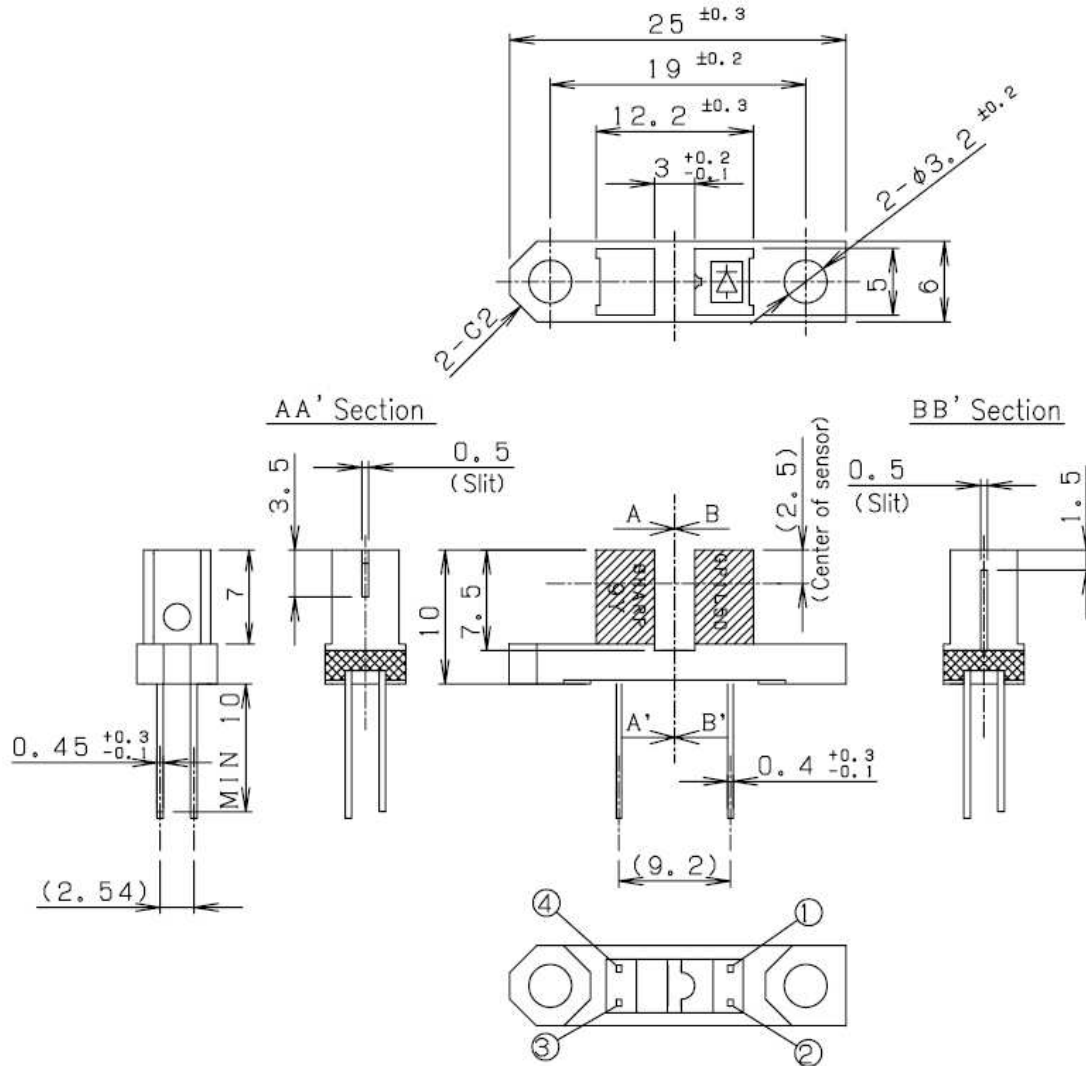

■ Absolute maximum ratings

Ta=25°C

Parameter		Symbol	Rating	Unit
Input	*1 Forward current	I _F	50	mA
	*1, 2 Peak forward current	I _{FM}	1	A
	Reverse voltage	V _R	6	V
	Power dissipation	P	75	mW
Output	Collector-emitter voltage	V _{CEO}	35	V
	Emitter-collector voltage	V _{ECO}	6	V
	Collector current	I _c	20	mA
	*1 Collector power dissipation	P _c	75	mW
Operating temperature		Topr	-25 to +85	°C
Storage temperature		Tstg	-40 to +100	°C
*3	Soldering temperature	Tsol	260	°C

- *1 The derating factors of absolute maximum ratings due to ambient temperature are shown in Fig. 1, 2, 3.
- *2 Pulse width ≤ 100μs, Duty ratio : 0.01
- *3 For 5s

■ Electro-optical Characteristics

Ta=25°C

Parameter		Symbol	Conditions	MIN.	TYP.	MAX.	Unit
Input	Forward voltage	V _F	I _F =20mA	-	1.25	1.4	V
	Peak forward voltage	V _{FM}	I _{FM} =0.5A	-	3	4	V
	Reverse current	I _R	V _R =3V	-	-	10	μA
Output	Dark current	I _{CEO}	V _{CE} =20V	-	1	100	nA
Transfer characteristics	Collector current	I _c	V _{CE} =5V, I _F =20mA	0.5	-	5.0	mA
	Collector-emitter saturation voltage	V _{CE(sat)}	I _F =40mA, I _c =0.5mA	-	-	0.4	V
	Response time (Rise)	tr	V _{CE} =2V, I _c =2mA R _L =100Ω	-	3	15	μs
	Response time (Fall)	tf		-	4	20	μs

(Test circuit for response time)

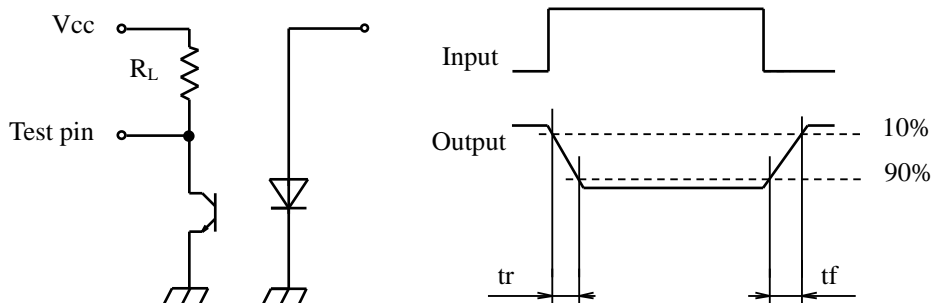

Fig.1 Forward current vs. ambient temperature

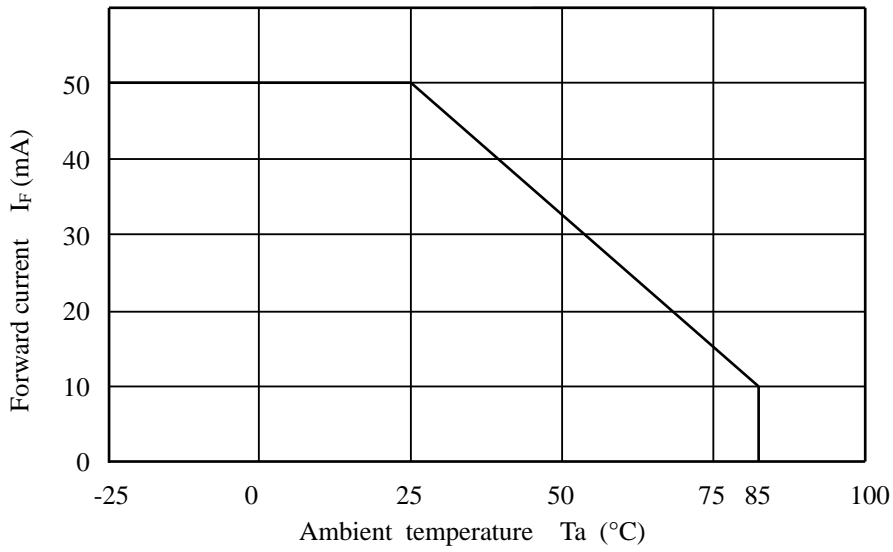

Fig.2 Collector power dissipation vs. ambient temperature

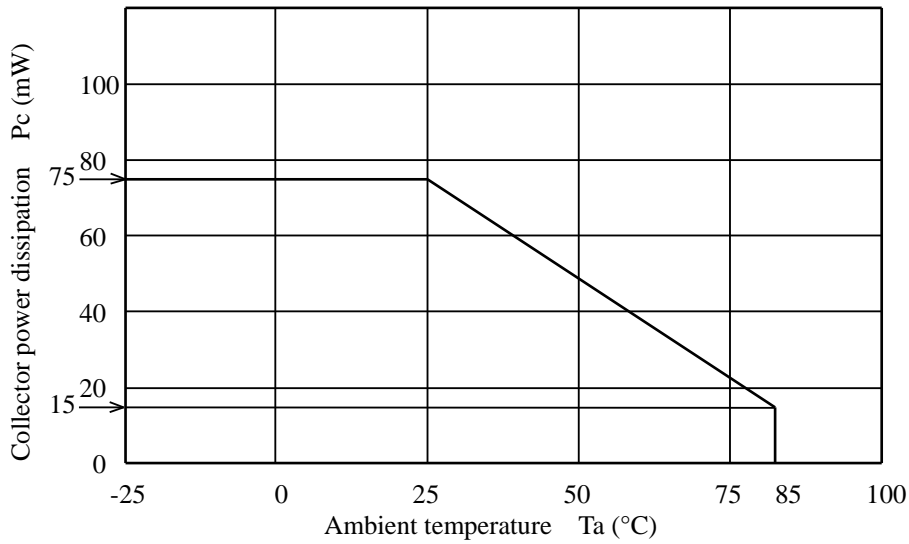
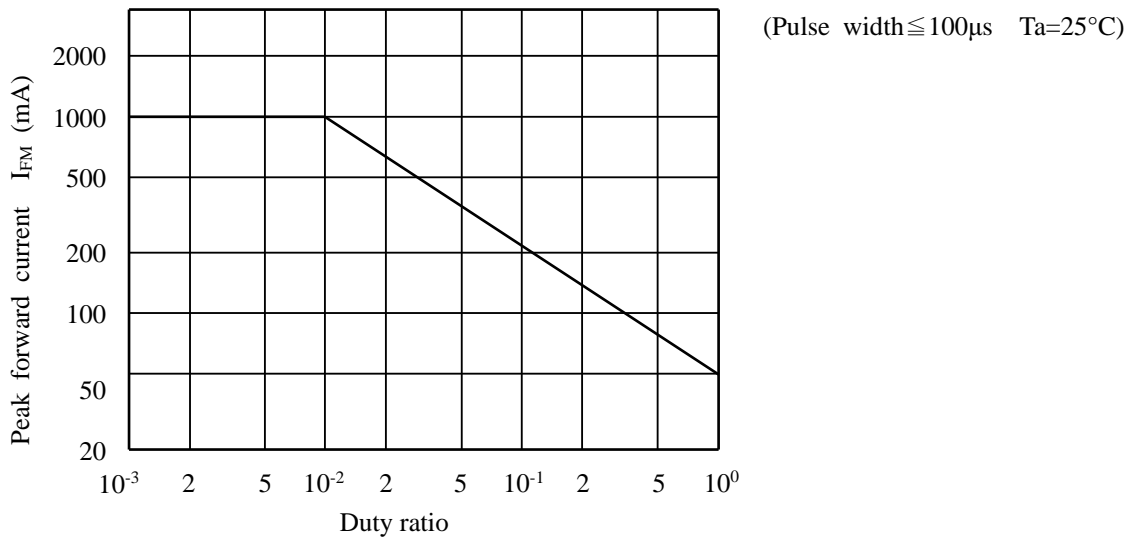

Fig.3 Peak forward current vs. duty ratio



■ **Supplements**

● **Parts**

This product uses the below parts.

1) Light detector (PT480, Quantity : 1)

Type	Material	Maximum sensitivity wavelength (nm)	Sensitivity wavelength (nm)	Response time (μs)
Phototransistor	Silicon (Si)	800	400 to 1200	3

2) Light emitter (GL480, Quantity : 1)

Type	Material	Maximum light emitting wavelength (nm)	I/O Frequency (MHz)
Infrared light emitting diode (non-coherent)	GaAs	950	0.3

3) Material

Case	Lead flame finish
Black NORYL resin	Solder dip (Sn-3.0Ag-0.5Cu)

4) Others

This product shall not be proof against radiation flux.

● **ODS materials**

This product shall not contain the following materials.

Also, the following materials shall not be used in the production process for this product.

Materials for ODS : CFCs, Halon, Carbon tetrachloride, 1.1.1-Trichloroethane (Methylchloroform)

● **Brominated flame retardants**

Specific brominated flame retardants such as the PBB_Os and PBB_Ss are not used in this device at all.

● **RoHS restriction**

This product does not contain LEAD(Pb) more than RoHS restriction level.

Object : Lead, hexavalent chromium, cadmium, mercury, and two types of brominated fire retardants (PBB, PBDE).

● **Product mass : Approx. 0.7g**

● **Country of origin : Japan, Indonesia, Philippine**

■Notes

●Circuit design

In circuit designing, make allowance for the degradation of the light emitting diode output that results from long continuous operation. (50% degradation/5 years)

●Position of opaque board

Opaque board shall be installed at place 4mm or more from the top of elements.

(Example)

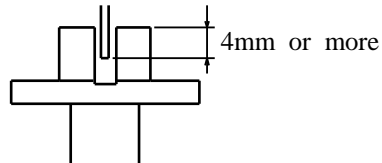

●Soldering

To solder onto lead pins, solder at 260°C for 5 seconds or less.

Please take care not to let any external force exert on lead pins when soldering or just after soldering.

Please don't do soldering with preheating, and please don't do soldering by reflow.

●Cleaning conditions :

(1) Solvent cleaning : Solvent temperature 45°C or less

Immersion 3 min. or less

(2) Ultrasonic cleaning : The effect to device by ultrasonic cleaning differs by cleaning bath size, ultrasonic power output, cleaning time, PCB size or device mounting condition etc.

Please test it in actual using condition and confirm that doesn't occur any defect before starting the ultrasonic cleaning.

(3) Applicable solvent : Ethyl alcohol, Methyl alcohol, Isopropyl alcohol

●Flux

Some flux, which is used in soldering, may crack the package due to synergistic effect of alcohol in flux and the rise in temperature by heat in soldering. Therefore, in using flux, please make sure that it does not have any influence on appearance and reliability of the photointerrupter.

■ Important Notices

· The circuit application examples in this publication are provided to explain representative applications of SHARP devices and are not intended to guarantee any circuit design or license any intellectual property rights. SHARP takes no responsibility for any problems related to any intellectual property right of a third party resulting from the use of SHARP's devices.

· Contact SHARP in order to obtain the latest device specification sheets before using any SHARP device. SHARP reserves the right to make changes in the specifications, characteristics, data, materials, structure, and other contents described herein at any time without notice in order to improve design or reliability. Manufacturing locations are also subject to change without notice.

· Observe the following points when using any devices in this publication. SHARP takes no responsibility for damage caused by improper use of the devices which does not meet the conditions and absolute maximum ratings to be used specified in the relevant specification sheet nor meet the following conditions:

(i) The devices in this publication are designed for use in general electronic equipment designs such as:

- Personal computers
- Office automation equipment
- Telecommunication equipment [terminal]
- Test and measurement equipment
- Industrial control
- Audio visual equipment
- Consumer electronics

(ii) Measures such as fail-safe function and redundant design should be taken to ensure reliability and safety when SHARP devices are used for or in connection

with equipment that requires higher reliability such as:

- Transportation control and safety equipment (i.e., aircraft, trains, automobiles, etc.)
- Traffic signals
- Gas leakage sensor breakers
- Alarm equipment
- Various safety devices, etc.

(iii) SHARP devices shall not be used for or in connection with equipment that requires an extremely high level of reliability and safety such as:

- Space applications
- Telecommunication equipment [trunk lines]
- Nuclear power control equipment
- Medical and other life support equipment (e.g., scuba).

· If the SHARP devices listed in this publication fall within the scope of strategic products described in the Foreign Exchange and Foreign Trade Law of Japan, it is necessary to obtain approval to export such SHARP devices.

· This publication is the proprietary product of SHARP and is copyrighted, with all rights reserved. Under the copyright laws, no part of this publication may be reproduced or transmitted in any form or by any means, electronic or mechanical, for any purpose, in whole or in part, without the express written permission of SHARP. Express written permission is also required before any use of this publication may be made by a third party.

· Contact and consult with a SHARP representative if there are any questions about the contents of this publication.